

WAT-100N

Monochrome camera "NEPTUNE 100"

【SPECIFICATIONS】

Model	WAT-100N (EIA / CCIR)
Pick-up element	1/2inch Interline transfer CCD image sensor
Number of total pixels	811(H) × 508(V) : (EIA) 795(H) × 596(V) : (CCIR)
Number of effective pixels	768(H) × 494(V) : (EIA) 752(H) × 582(V) : (CCIR)
Unit cell size	8.4 μm(H) × 9.8 μm(V) : (EIA) 8.6 μm(H) × 8.3 μm(V) : (CCIR)
Scanning system	2:1 interlace
Synchronizing system	Internal
Video output	Composite Video, 1 Vp-p, 75ohm Unbalanced
Resolution(Horizontal)	570 TV lines
Minimum illumination	0.001 lx. F1.4
Gamma correction	≒1.0(OFF), ≒0.45, ≒0.65
AGC	5~42dB
S/N Ratio	50dB (AGC OFF)
Shutter speeds	OFF, FL, 1/250, 1/500, 1/1000, 1/2000, 1/5000, 1/10000, 1/100000 sec. (WAT-100NRM)
Lens mount	CS-mount
Installation screw	U 1/4 (D=5mm) (Top/Bottom)
Connection terminal	Video out(BNC), Power, Auto iris, Remote control(R.C.)
Power supply	DC +10.8~13.2V (12V±10%)
Current	max. 100mA
Operating temperature	-10°C ~ +40°C
Storage temperature	-30°C ~ +70°C
Dimensions	42.0(W) × 44.0(H) × 53.0(D)mm
Weight	Approx. 125g
Accessories	Remote control box(WAT-100NRM), DC-plug(WPDC12) Iris-plug(AIC), C-Mount adaptor(34CMA-R) Hex key wrench

【DIMENSIONS】

Camera Unit (WAT-100N)

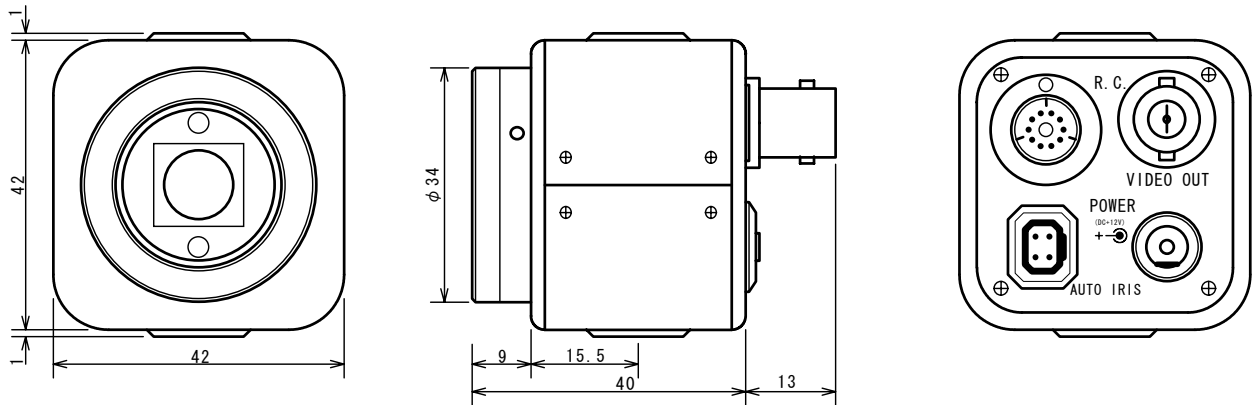

Remote control Unit (WAT-100NRM)

